

FAMILY FUN!

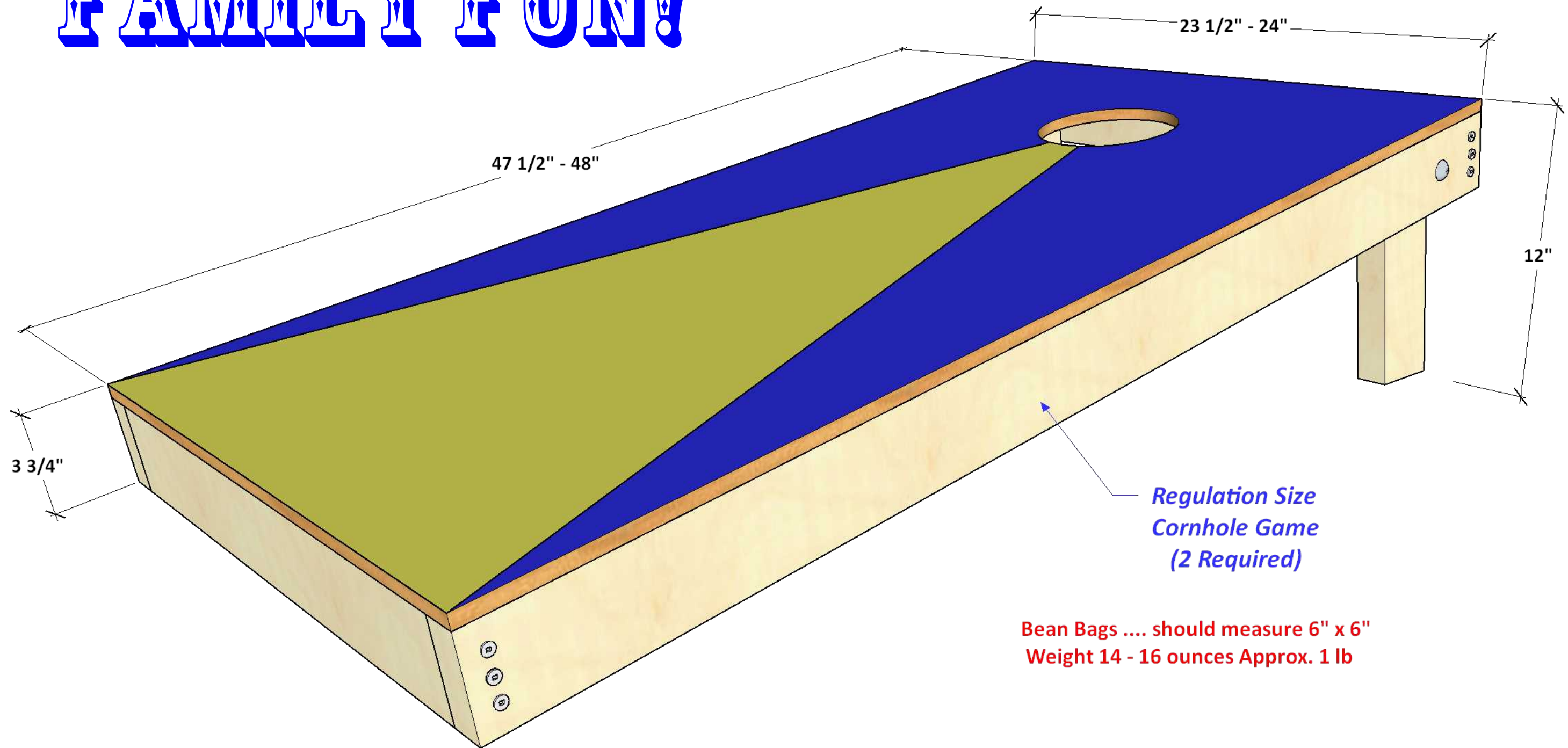

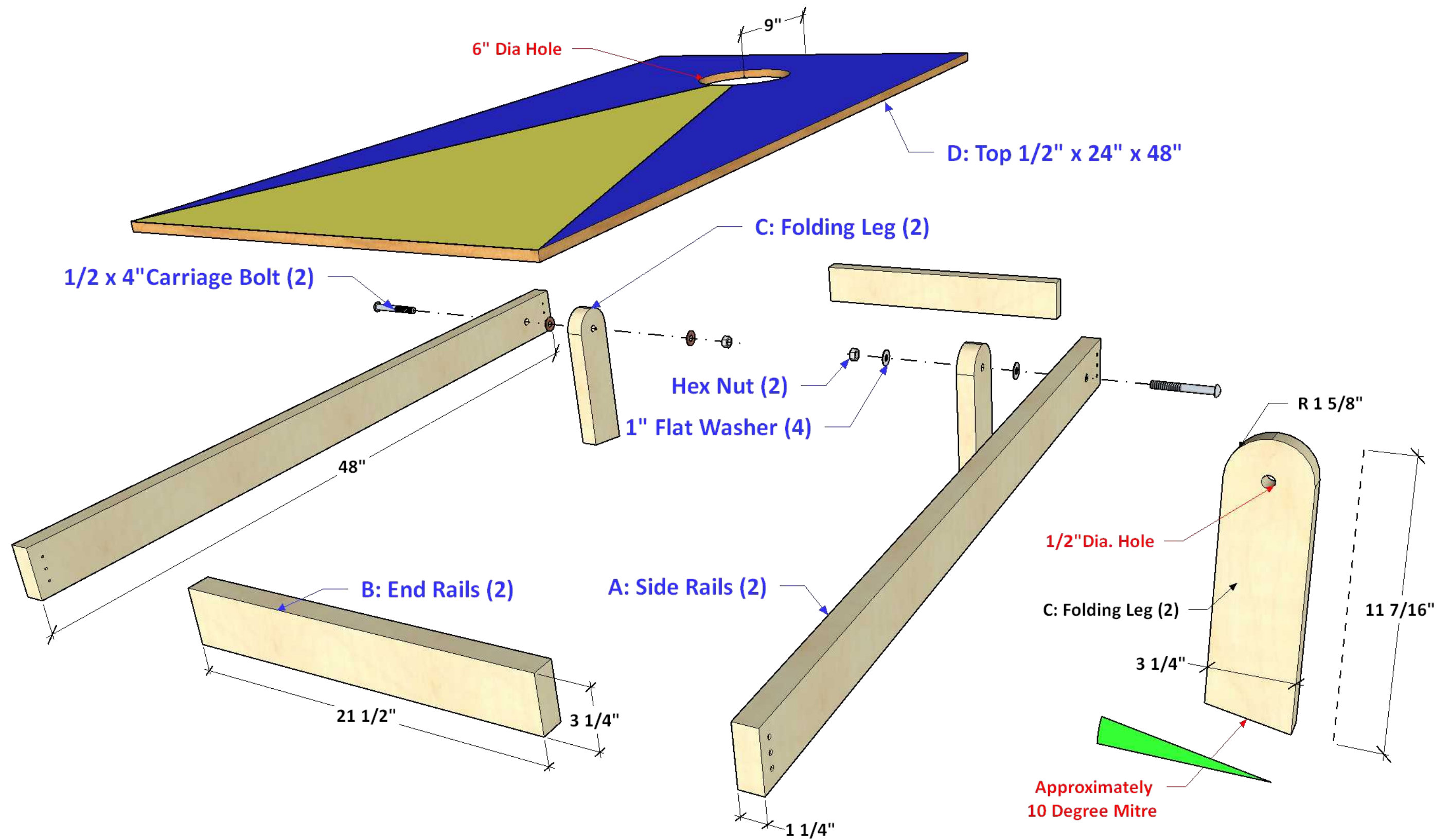

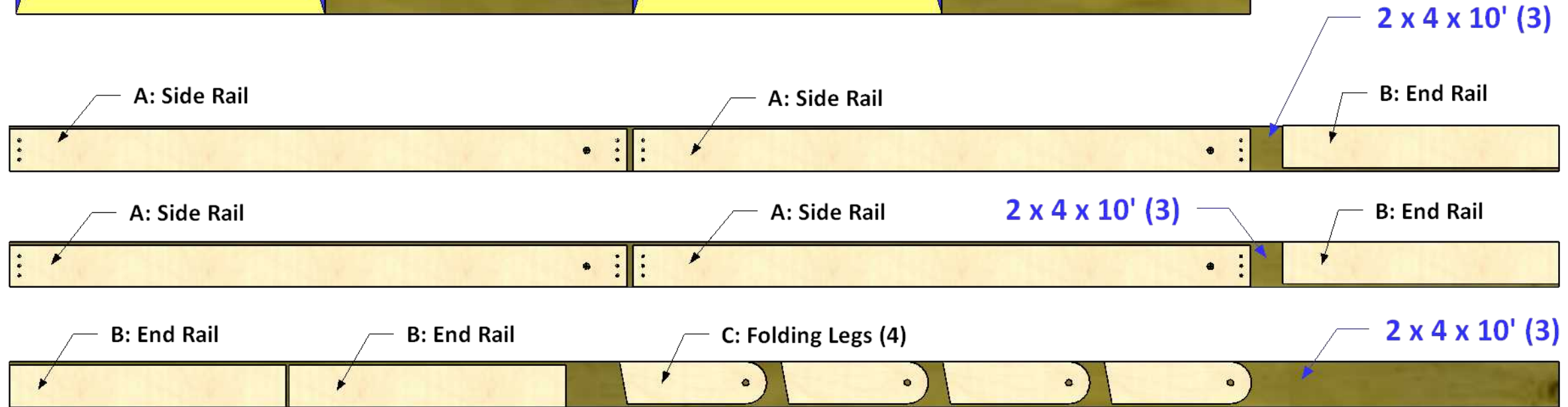
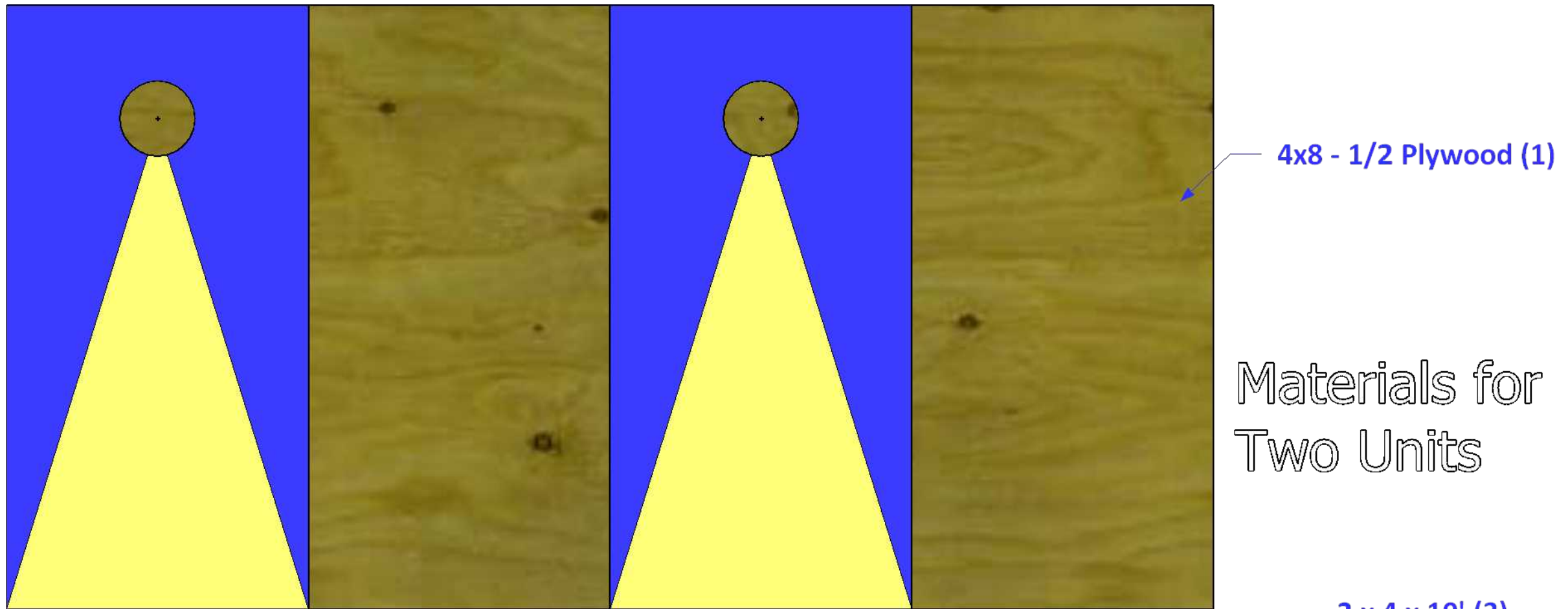

Cornhole Game Rules

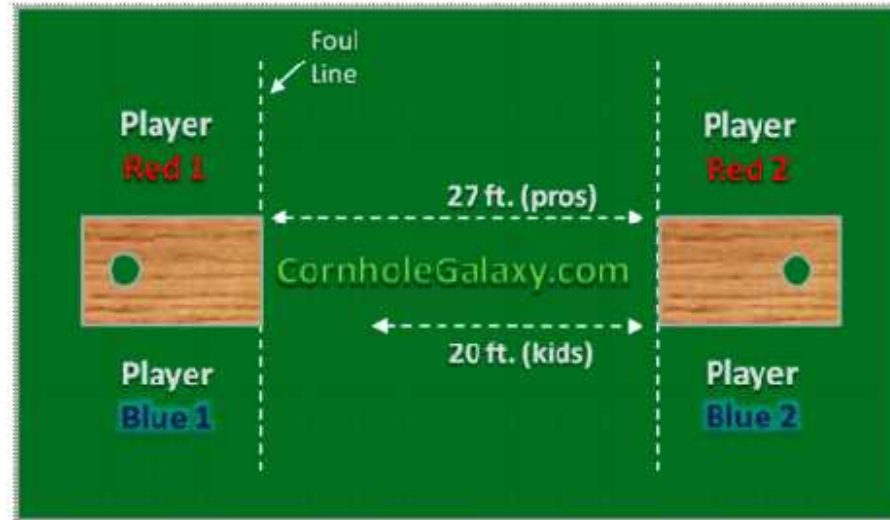

The rules for the game of Cornhole are fairly simple and straightforward. Cornhole is a game that can be picked up in just a few minutes, with very little instruction time necessary. This is one of the primary reasons why so many people enjoy this new sport; it isn't rocket science folks. It is, however, highly addictive, and great for people of all ages. In just a few short years, Cornhole has claimed the title as the "King of Backyard Sports." No offense to other lawn games such as horseshoes or croquet, but Cornhole reigns supreme.

For those of you who are unfamiliar with the sport and want to know what the big deal is, here are the basic rules of the game.

Equipment

- Two Cornhole Boards
 - 24" x 48" playing surface (made of strong plywood)
 - 6" hole, with hole center 9" from back of board
 - Back of board propped up 12" off the ground
 - Front of board 4" off the ground
- 8 Cornhole Bags (4 of one color, 4 of another)
 - 6" x 6"
 - Each bag filled with 14-16 oz (1 lb) of whole kernel corn
 - Made of duck canvas fabric
- Beverage of your choice

Players

- One-on-One – Play side by side, be prepared to walk back and forth between boards.
- Doubles – Two teams of two players. Players on same team play opposite each other. (See picture above)

Playing Area

- Place front of boards a distance of **27 feet** apart on a level ground.
- Avoid playing under low-lying branches or other obstacles.
- Each player stands in his designated playing area next to the board.
- Do not cross the foul line (front of board) while tossing.

Tossing Sequence/Rounds

- Flip a coin or a beer bottle cap to see which team starts first.
- Bags are tossed alternately between opposing players on one side until each has thrown four bags downrange.
- When all 8 bags are thrown, points are then calculated, and this completes one round of play. Bags are then tossed back in the same fashion.
- The team who scored the most points in the last round, begins the tossing in the next round.

Points and Scoring Structure

- First team to **21** wins. Even if one team has already scored 21 points, the other team must be allowed to complete their tosses in that round to see if they can top 21. Win-by-two scoring is optional.
- **3 points** ("ringer") – A bag falls into the hole, by way of:
 - A direct shot into the hole, a "swish" per se.
 - Slides across the board and falls into hole.
 - Is knocked in by another tossed bag from either team.
- **1 point** – A bag that simply lands on the board and remains there.
- A bag that hits the grass or ground in front of the board and bounces onto the board is not permitted. The bag must be removed from the playing surface immediately and it will not factor in the point calculations.
- A bag that is resting half on the board and half on the grass does not count for any points. Bags must be fully on the board.
- Any bag knocked off the board is also zero points.

Point Cancellation

- Cornhole is scored by way of point cancellation, not total points accumulated.
- A 3-pointer (ringer) cancels out an opponent's 3 points.
- A 1-pointer (on the board) cancels out an opponent's 1 point, and so forth.
- To make it simple, if Team Red scores a total of 7 points, and Team Blue scores a total of only 3 points, then Team Red has garnered 4 points. Team Blue now has the blues.